

(Model.)

2 Sheets—Sheet 1.

L. D. NOBLITT.
SAWING MACHINE.

No. 246,540.

Patented Aug. 30, 1881.

Fig. 1.

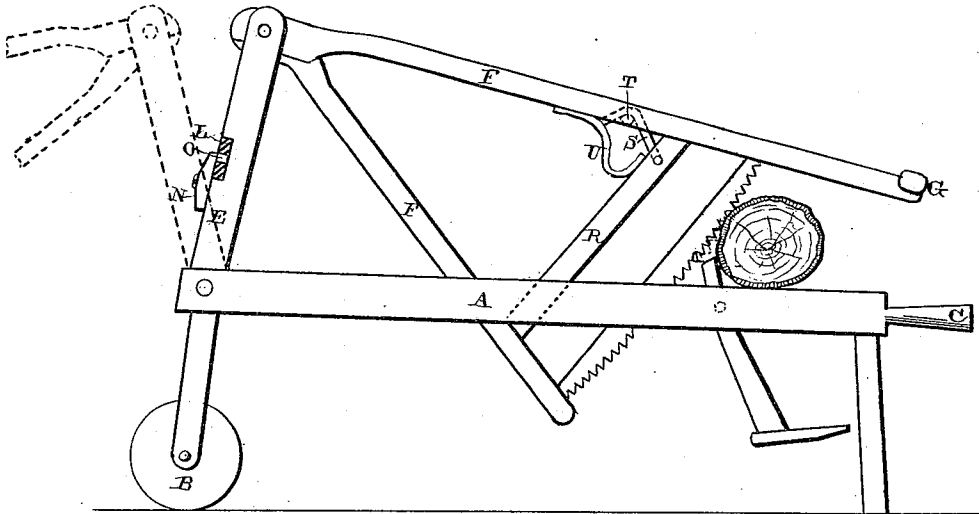
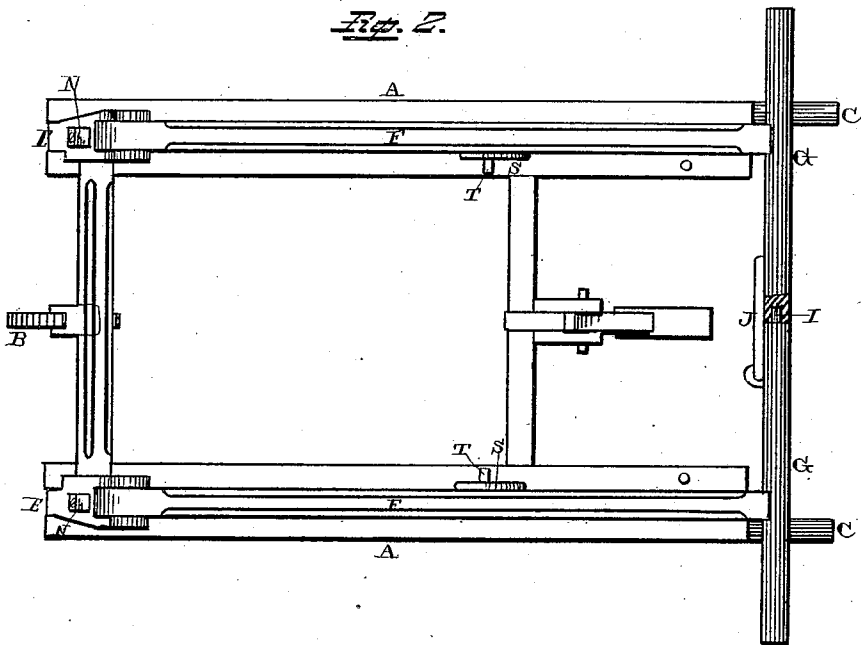

Fig. 2.



Witnesses.

Wm W. Mortimer.
A. Q. Kiskadden.

Inventor

L. D. Noblitt.
per
F. A. Lehmann, atty.

(Model.)

2 Sheets—Sheet 2.

L. D. NOBLITT.

SAWING MACHINE.

No. 246,540.

Patented Aug. 30, 1881.

Fig. 5.

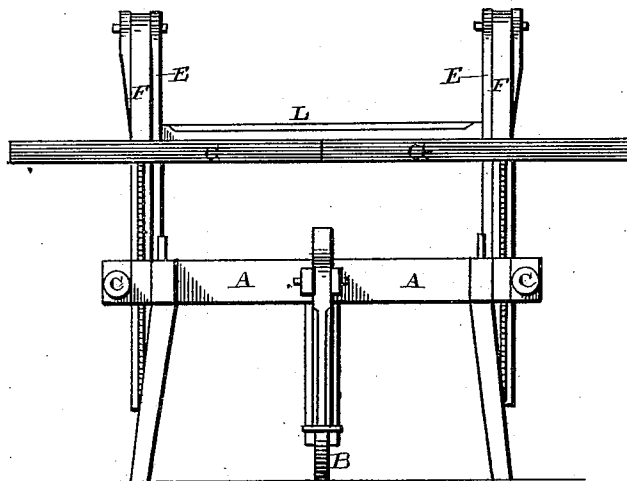
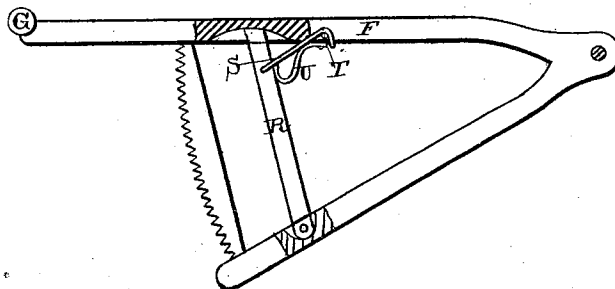

Fig. 4.



WITNESSES.

W. W. Mortimer.
A. G. Kiskadden

INVENTOR.

L. D. Noblitt
per
F. W. Lehmann,
atty

UNITED STATES PATENT OFFICE.

LAZARUS D. NOBLITT, OF KIRKSVILLE, MISSOURI, ASSIGNOR OF ONE-THIRD
TO S. A. MILLER, OF ALTO, INDIANA.

SAWING-MACHINE.

SPECIFICATION forming part of Letters Patent No. 246,540, dated August 30, 1881.

Application filed July 16, 1881. (Model.)

To all whom it may concern:

Be it known that I, LAZARUS D. NOBLITT, of Kirksville, in the county of Adair and State of Missouri, have invented certain new and useful Improvements in Sawing-Machines; and I do hereby declare the following to be a full, clear, and exact description of the invention, such as will enable others skilled in the art to which it pertains to make and use it, reference being had to the accompanying drawings, which form part of this specification.

My invention relates to an improvement in sawing-machines; and it consists in the arrangement and combination of devices whereby two saws are connected together so that they will be operated at the same time, and whereby they may be disconnected and either one thrown back so as to allow the other one to be used alone.

The object of my invention is to produce a sawing-machine in which two saws can be operated at the same time or either one alone, and in which the saws may be tightened up when in use and relaxed when idle, so that the saw will not be injured by being kept constantly stretched.

Figure 1 is a side elevation of my invention. Fig. 2 is a plan view of the same. Fig. 3 is a rear view. Fig. 4 is a detail view of the brace which is used for tightening the saw.

A represents the frame, which is supported upon its rear end by a wheel, B; and which is provided with a handle, C, at the other end, so that the machine can be moved around like a wheelbarrow. The timbers upon each of the two sides of the frame are made double, and in between these two timbers, upon each side, is pivoted a standard, E, which has its upper end bifurcated, and in this upper end is pivoted the saw-frame F. This saw-frame works between the double timbers on the side of the frame, and is thus kept always straight and true in its movements, so as to prevent any lateral strain upon the joints. There are two of these saw-frames, and each one is provided with a handle, G, of its own on its front end, and one of these handles is provided with a projection, I, which fits in a corresponding

socket that is made in the end of the other handle. When it is desired that both saws should be used together this projection is passed into the tenon made to receive it, and then the two handles are rigidly locked together by means of the hook J. At the same time that the handles are locked together a cross-brace, L, is applied to the two pivoted standards to which the saw-frames are secured, and this cross-brace locks the standards together in such a manner that the two saws will move together as if one. This brace has a tenon formed upon each end, so as to fit in a corresponding recess which is made in the uprights to receive it. Projecting out from the center of each one of these recesses is a projection, O, which projection passes through a hole which is made in the end of the cross-brace. After the ends of the brace have been fitted in position a button, N, is turned up over them, so as to hold the ends rigidly in position.

When it is desired to use only one saw at a time the handles are separated at their front ends, the cross-brace is removed, and then one of the saws can be swung back out of the way, as shown in dotted lines in Fig. 1.

As it is very desirable to have the saws stretched while in operation and to relax them while not in use, so that the saws will not be injured by being constantly strained, the cross-braces R in the saw-frames are pivoted at their lower ends to the frame and have their upper ends made movable, as shown. When the brace is not drawn tightly into position the frame will relax sufficiently to allow the saw to remain unstretched; but when the brace is drawn forward, so that the hook S will catch upon the projection T, the two parts of the frame are forced asunder, so as to stretch the saw. In order to prevent this brace from becoming disconnected from the frame, a strap, U, is connected to the frame at one end and to the brace at the other, so that the brace can be moved but a very slight distance. By means of this adjustable frame and its hook the saws can be stretched whenever they are about to be used, and then relaxed as soon as there is no further use for them. In this way

there is no necessity for the saws ever being injured by being kept constantly stretched.

Having thus described my invention, I claim—

5 The combination of the frame, the two pivoted standards, the removable cross-brace, and the two handles which are fastened to the front ends of the two saw-frames, and a suit-

able hook, whereby their inner ends are fastened together, substantially as described. 10

In testimony whereof I affix my signature in presence of two witnesses.

LAZARUS DENNY NOBLITT.

Witnesses:

J. S. HILL,

W. J. RICHEY.